

FCC Part 15B Test Report

Application No. : HX1904018108
Applicant : Shenzhen Red Star Electronics Co., Ltd.
Equipment Under Test (EUT)
EUT Name : Y-type 3in1 light up cable
Model No. : RXD-L408TG
Serial No. : See Page 3
Brand Name : N/A
Receipt Date : 2019-04-20
Test Date : 2019-04-20 to 2019-04-30
Issue Date : 2019-04-30
Standards : FCC Part 15: 2018 Subpart B
Conclusions : **PASS**

In the configuration tested, the EUT complied with the standards specified above. The EUT technically complies with the FCC requirements

Test/Witness Engineer : *Tim Chen*

Approved & Authorized : *Andy Zhang*



This report details the results of the testing carried out on one sample. The results contained in this test report do not relate to other samples of the same product. The manufacturer should ensure that all products in series production are in conformity with the product sample detailed in the report.

Contents

CONTENTS.....	2
1. GENERAL INFORMATION	3
1.1 Client Information	3
1.2 General Description of EUT (Equipment Under Test).....	3
1.3 Block Diagram Showing The Configuration of System Tested.....	3
1.4 Test standards.....	3
1.5 Test Facility	4
1.6 Equipment Used Test.....	4
2. TEST SUMMARY	5
3. CONDUCTED EMISSION TEST	6
3.1 Test Standard and Limit.....	6
3.2 Test Setup.....	6
3.3 Test Procedure	6
3.4 Test Data.....	7
4. RADIATED EMISSION TEST	8
4.1 Test Standard and Limit.....	8
4.2 Test Setup.....	8
4.3 Test Procedure	8
4.4 Test Condition	9
4.5 Test Data.....	9
5. PHOTOGRAPHS - CONSTRUCTIONAL DETAILS	12

1. General Information

1.1 Client Information

Applicant	:	Shenzhen Red Star Electronics Co., Ltd.
Address	:	Jinyu Alley NO.1-8, Sifang Pu Community, Ping Di Street, Longgang
Manufacturer	:	Shenzhen Red Star Electronics Co., Ltd.
Address	:	Jinyu Alley NO.1-8, Sifang Pu Community, Ping Di Street, Longgang

1.2 General Description of EUT (Equipment Under Test)

EUT Name	:	Y-type 3in1 light up cable
Model No.	:	RXD-L408TG
Serial No.	:	RXD-L409TG, RXD-L10TG, RXD-C28TG
Brand Name	:	N/A
Power Supply	:	DC5.0V, 1A
Remark: All above models are identical in schematic, structure and critical components except for only different appearance; therefore, EMI testing was performed with RXD-L408TG only.		

1.3 Block Diagram Showing The Configuration of System Tested

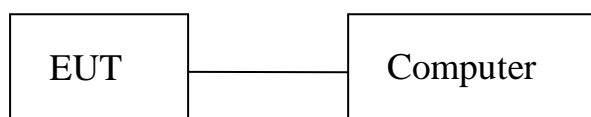

1.4 Test standards

The objective is to determine compliance with FCC Part 15, Subpart B, and section 15.107, 15.109 rules.

Maintenance of compliance is the responsibility of the manufacturer. Any modification of the product, which result in lowering the emission, should be checked to ensure compliance has been maintained.

1.5 Test Facility

The testing report were performed by the Shenzhen HX Detect Certification Co., Ltd., in their facilities located at 8/F, Haoyunlai Building B, Baomin 2th Road, Xixiang Street, Baoan District, Shenzhen, China.

1.6 Equipment Used Test

1.6.1 Test Equipment Used to Measure Conducted Emission

No.	Equipment	Manufacturer	Model No.	Last Cal.	Cal. Interval
HX-EMC001	EMI Test Receiver	Rohde & Schwarz	ESCS30	Jan.02, 2019	1 Year
HX-EMC002	AMN	Rohde & Schwarz	ENV216	Jan.02, 2019	1 Year
HX-EMC003	AMN	SCHWARZBECK	NNBL 8226-2	Jan.02, 2019	1 Year

1.6.2 Test Equipment Used to Measure Radiated Emission

No.	Equipment	Manufacturer	Model No.	Last Cal.	Cal. Interval
HX-EMC004	EMI Test Receiver	Rohde & Schwarz	ESI26	Jan.02, 2019	1 Year
HX-EMC005	Bilog Antenna	SCHWARZBECK	VULB9163	Jan.02, 2019	1 Year
HX-EMC006	Positioning Controller	C&C	CC-C-1F	N/A	N/A

2. Test Summary

Test Items	Test Requirement	Test Method	Result
Conducted Emission	FCC Part 15: 2018 Subpart B	ANSI C63.4	N/A
Radiated Emission	FCC Part 15: 2018 Subpart B	ANSI C63.4	Pass

Note: N/A is an abbreviation for Not Applicable.

3. Conducted Emission Test

3.1 Test Standard and Limit

3.1.1 Test Standard

FCC Part 15 B: 2018

3.1.2 Test Limit

Conducted Emission Test Limit (Class B)

Frequency	Maximum RF Line Voltage (dB μ V)	
	Quasi-peak Level	Average Level
150kHz~500kHz	66 ~ 56 *	56 ~ 46 *
500kHz~5MHz	56	46
5MHz~30MHz	60	50

*decreasing linearly with logarithm of the frequency

3.2 Test Setup

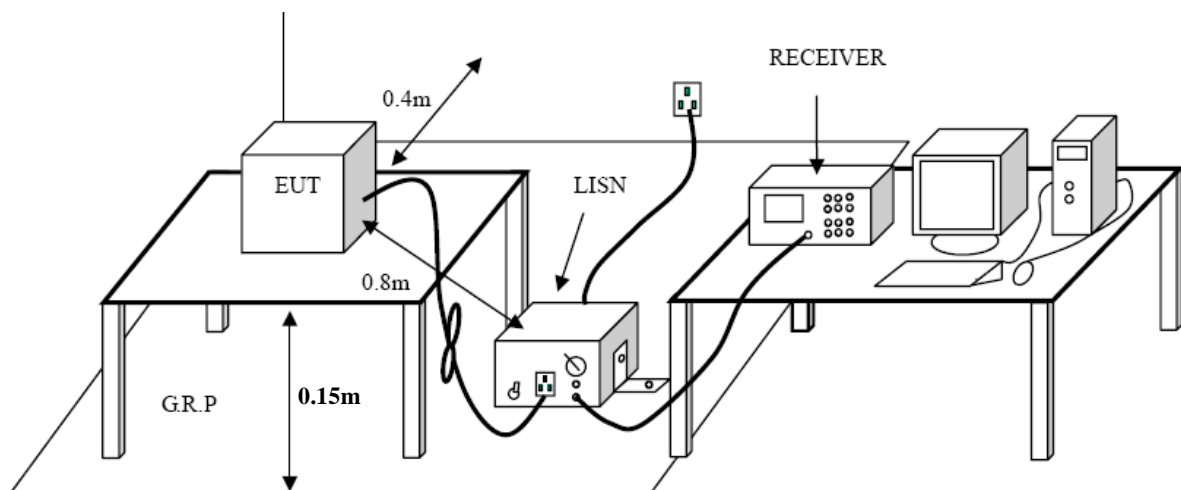

3.3 Test Procedure

The EUT was placed 0.15 meters from the horizontal ground plane with EUT being connected to the power mains through a line impedance stabilization network (LISN). All other support equipments powered from additional LISN(s). The LISN provide 50 Ohm/ 50uH of coupling impedance for the measuring instrument.

The cables shall be insulated (by up to 15 cm) from the horizontal ground reference plane, and shall be folded back and forth in the center forming a bundle 30 to 40 cm long.

I/O cables that are not connected to a peripheral shall be bundled in the center. The end of the cable may be terminated, if required, using the correct terminating impedance. The overall length shall not exceed 1 m.

LISN at least 80 cm from nearest part of EUT chassis.

The bandwidth of EMI test receiver is set at 9kHz, and the test frequency band is from 0.15MHz to 30MHz.

3.4 Test Data

This test is not applicable.

4. Radiated Emission Test

4.1 Test Standard and Limit

4.1.1 Test Standard
FCC Part 15 B: 2018

4.1.2 Test Limit

Radiated Emission Test Limit (Class B)

Frequency MHz	Field Strengths Limits dB(μ V/m)
30 ~ 88	40.0
88 ~ 216	43.5
216 ~ 960	46.0
960 ~ 1000	54.0

* The lower limit shall apply at the transition frequency.

* The test distance is 3m.

4.2 Test Setup

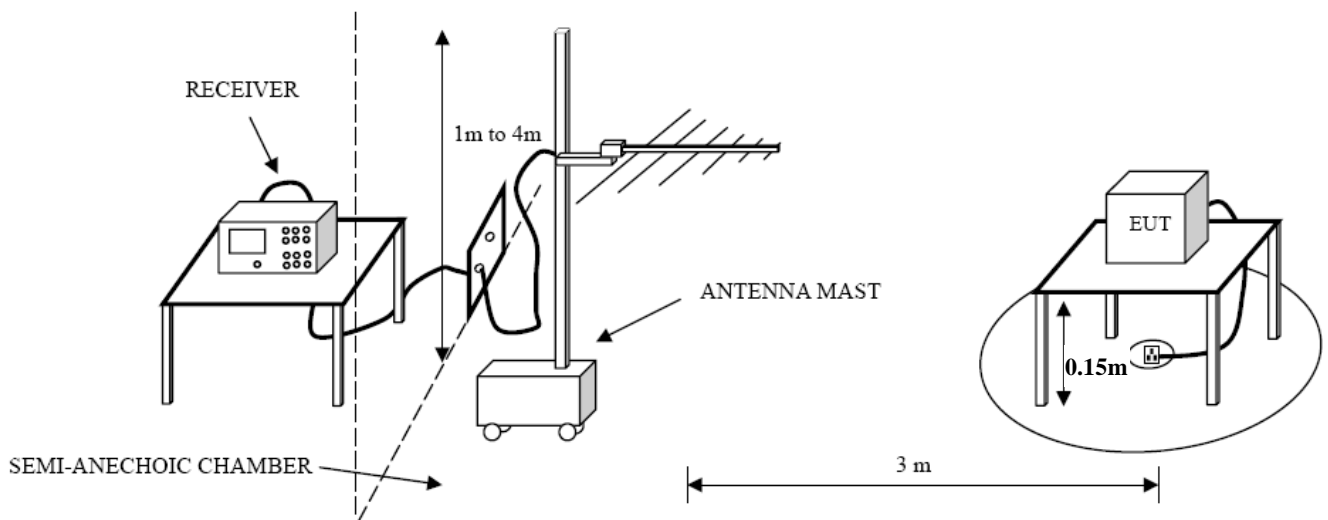

4.3 Test Procedure

The EUT was placed on the top of a rotating table which is 0.15 meters above the ground. EUT is set 3.0 meters away from the receiving antenna that mounted on a antenna tower. The table was rotated 360 degrees to determine the position of the highest radiation, the antenna can be moved up and down between 1.0 meter and 4 meters to find out the maximum emission level. Both horizontal and vertical polarizations of the antenna are set to make the measurement.

Measurements shall be made with a quasi-peak measuring receiver in the frequency range

30MHz to 1000MHz. If the Peak Mode measured value compliance with and lower than quasi-peak mode Limit, the EUT shall be deemed to meet QP Limits and then no additional QP Mode measurement performed.

4.4 Test Condition

Temperature	:	25 °C
Relative Humidity	:	48 %
Pressure	:	1010 hPa
Test Power	:	DC 5V

4.5 Test Data

Please refer to the following pages.

Operating Condition: Normal

Test Specification: Horizontal

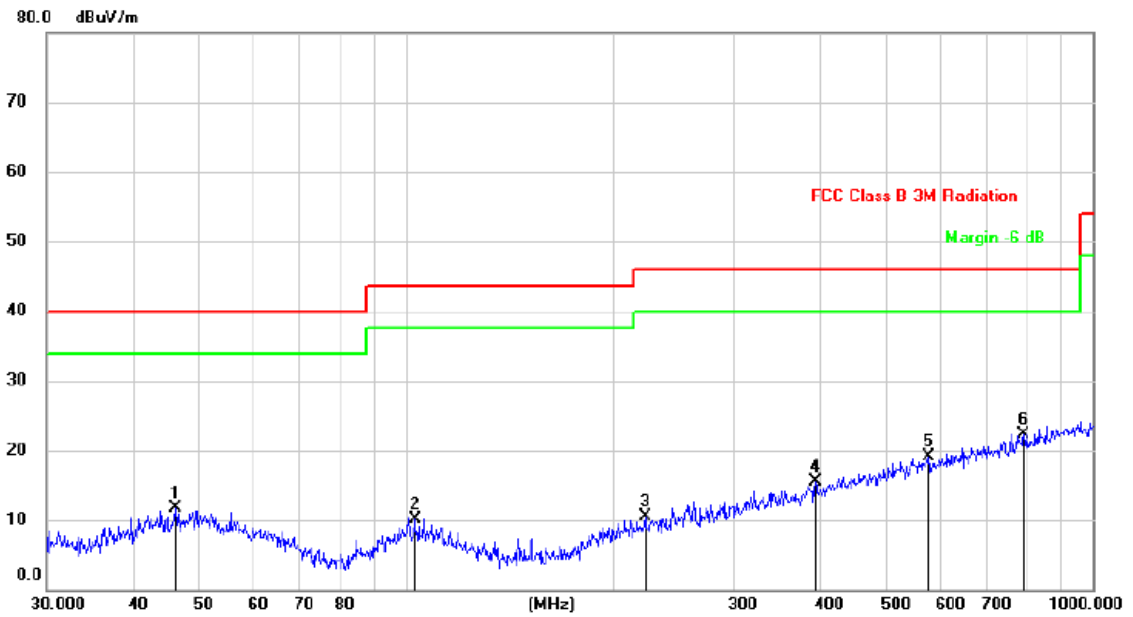

No.	Mk.	Freq. MHz	Reading Level dBuV	Correct Factor dBuV/m	Measure- ment dBuV/m	Limit dBuV/m	Over dB	Detector
1		46.1779	24.33	-12.69	11.64	40.00	-28.36	QP
2		103.0800	24.49	-14.44	10.05	43.50	-33.45	QP
3		222.9500	23.47	-12.94	10.53	46.00	-35.47	QP
4		394.8543	24.15	-8.66	15.49	46.00	-30.51	QP
5		576.6443	24.88	-5.75	19.13	46.00	-26.87	QP
6	*	793.3958	25.28	-2.89	22.39	46.00	-23.61	QP

Operating Condition: Normal

Test Specification: Vertical

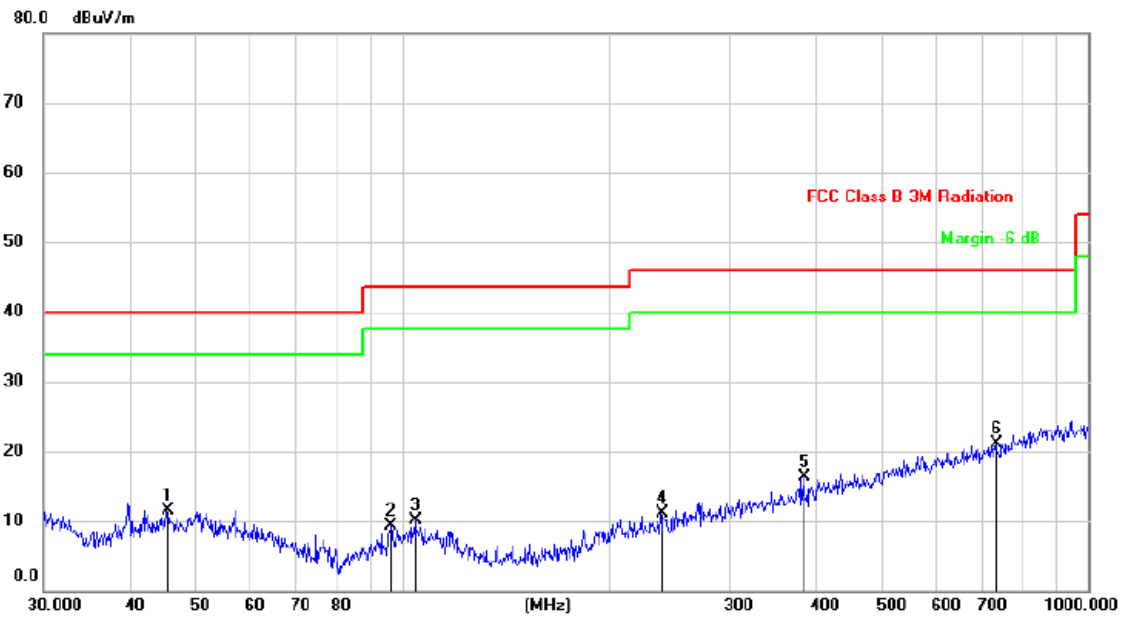

No.	Mk.	Freq. MHz	Reading Level dBuV	Correct Factor dBuV/m	Measure- ment dBuV/m	Limit dBuV/m	Over dB	Detector
1		45.3755	24.23	-12.70	11.53	40.00	-28.47	QP
2		96.4360	24.43	-15.03	9.40	43.50	-34.10	QP
3		104.5361	24.54	-14.44	10.10	43.50	-33.40	QP
4		238.3102	23.46	-12.42	11.04	46.00	-34.96	QP
5		385.2805	25.07	-8.84	16.23	46.00	-29.77	QP
6	*	734.4913	24.78	-3.74	21.04	46.00	-24.96	QP

5. Photographs - Constructional Details

Photo 1 Appearance of EUT



END OF REPORT